

easy **TRX** **3 S**

**AIS Class B SOTDMA
ME SENSE Yacht-Monitoring**

User Guide

V1.0m
English



1 Notes

1.1 Safety instructions

All maritime AIS devices use satellite-based systems such as the GPS (Global Positioning System) or the GLONASS network to determine their position. The accuracy of these systems is variable and influenced by various factors, such as the antenna position, the number of satellites currently being received and the time the satellite information is already available. It is therefore desirable, wherever possible, to verify the AIS-derived positions of your own vessel, as well as those of other vessels, by observation and/or radar verification.

The easyTRX3 software is to be used as an installation and configuration tool. The application is not navigation software and must not be used as such.

1.2 License (MMSI) for AIS Class B

In many countries, the operation of an AIS transmitter/receiver unit is regulated in accordance with VHF maritime radio regulations. The vessel that has an AIS Class B transmitter installed must be licensed, i.e. the call sign and MMSI number must be entered in the AIS system. Please contact the relevant authorities in your country for further information. In accordance with our corporate philosophy, our products are subject to constant further development. This means that the easyTRX3S product series and software can also be improved and updated from time to time. It is therefore possible that future versions of the easyTRX3S series may not be exactly the same in terms of operation as these operating instructions. For the necessary upgrades, the corresponding supplements to these operating instructions will be enclosed. Please take the time to read the operating instructions carefully in order to be able to use the devices of the easyTRX3S series in full depth and with all their possibilities.

1.3 Warning

When driving a vessel, it is the sole responsibility of the skipper to operate the vehicle in a safe manner and to have full control of all driving conditions at all times during the entire journey. Incorrect behaviour by the driver of a vehicle equipped with a device from the easyTRX3S series, where the driver does not pay full attention to the operation of the vehicle and the ambient conditions, can lead to an accident or collision resulting in damage to property or personal injury.

1.4 Registration Federal Network Agency (BSH)

The official form that you need to register with the Federal Network Agency for the operation of an AIS Class B transceiver in Germany can be found as a PDF file on their homepage:

<https://www.bundesnetzagentur.de/DE/Fachthemen/Telekommunikation/Frequenzen/SpezielleAnwendungen/Seefunk/DL/AntragNummernzuteilungSportschiffahrt.pdf?>

Please ask your dealer for the contact details of your local authority.

1.5 Approval number BSH

BSH/4542/001/4323246/18

1.6 Revision status of the operating instructions

Stand 1.0, Autor: Jürgen Zimmermann (CTO), Michael Knipp (Head of Marketing) 12/2024

Stand 1.1, Autor: Jürgen Zimmermann (CTO), Michael Knipp (Head of Marketing) 04/2025

Stand 1.2, Autor: Jürgen Zimmermann (CTO), Michael Knipp (Head of Marketing) 04/2026

1.7 Restrictions

At the current revision level, there are no known restrictions on the use of this AIS Class B transceiver easyTRX3S.

2 List of abbreviations:

Abbreviation	
AIS{ XE „AIS“ }	Automatic Identification System
CPA	Closest Point of Approach
LAN	Local Area Network
NMEA	National Marine Electronics Association
SSID	Service Set Identifier Device
VHF	Very High Frequency
VSWR	Voltage Standing Wave Ratio
WiFi	Wireless Fidelity -connect to a network by radio
GNSS	Global Navigation Satellite system (e.g. GPS, Galileo)
MMSI	Maritime Mobile Service Identity
HDOP	Horizontal Dilution of Precision

3 List of illustrations

Figure 1 Scope of Delivery	6
Figure 2 Connectors	8
Figure 3 Connection options and cable colours	9
Figure 4 RX only	10
Figure 5 external signalling device	11
Figure 6 Function overview for USB programming	Fehler! Textmarke nicht definiert.
Figure 7 Programming Software	12
Figure 45 NMEA2000 Messages	49
Figure 46 Technical Data	52
Figure 47 Connection Diagram	53
Figure 48 Troubleshooting	54
Figure 49 Error Messages.....	55

Content

1	Notes	2
1.1	Safety instructions	2
1.2	License (MMSI) for AIS Class B	2
1.3	Warning	2
1.4	Registration Federal Network Agency (BSH).....	2
1.5	Approval number BSH	2
1.6	Revision status of the operating instructions.....	3
1.7	Restrictions.....	3
2	List of abbreviations:.....	3
3	List of illustrations	3
4	Scope of Delivery	5
5	Short description easyTRX3S.....	7
6	Outstanding features of the easyTRX3S	7
7	Connection options	8
7.1	Standard.....	8
7.2	External Switches	10
7.2.1	RX only	10
7.2.2	External signalling device	10
8	Preparations.....	11
8.1	Via USB Connection to PC/MAC/Laptop	12
8.1.1	Connection.....	Fehler! Textmarke nicht definiert.
8.2	WiFi connection and app use with a mobile device	13
8.2.1	Functions via app.....	19
8.2.1.1	Transmitter	19
8.2.1.2	Long-Range AIS/Satellite AIS	20
8.2.1.3	Data Routing/Data Configuration.....	21
8.2.1.4	Target Filtering.....	23
8.2.1.5	Diagnostics.....	24
8.2.1.6	Anchor Alert	30
8.2.1.7	CPA Alert - Collision warning	32
8.2.1.8	Sent Data	34
8.3	ME SENSE	35
8.3.1	ME SENSE App	35
8.3.2	Basis-Version App.....	36
8.3.3	Abo-Version / in-app purchases.....	36
8.3.4	App installation ME SENSE	37
9	Integrated Modular Design	48

9.1	IS - integrated FM antenna splitter	48
9.2	IGPS - integrated GPS Antenna	48
9.3	N2K - integrated NMEA2000 Module	49
9.4	WiFi - integrated WiFi Modul	49
10	Optional Modular Design	49
10.1	DVBT - integrated antenna splitter for DVB-T2 and FM radio signals (optional).....	49
11	On-board installation of the easyTRX3S	50
12	Technical Data	50
13	Possible connection diagram.....	53
14	Fault diagnosis / Troubleshooting.....	54
15	Error Messages / Warning Messages	55
16	Maintenance.....	56
17	Contact and Support.....	56
18	Licence agreement	56
19	Warranty	57
20	WARNING.....	57
21	Your Notes	58

4 Scope of Delivery



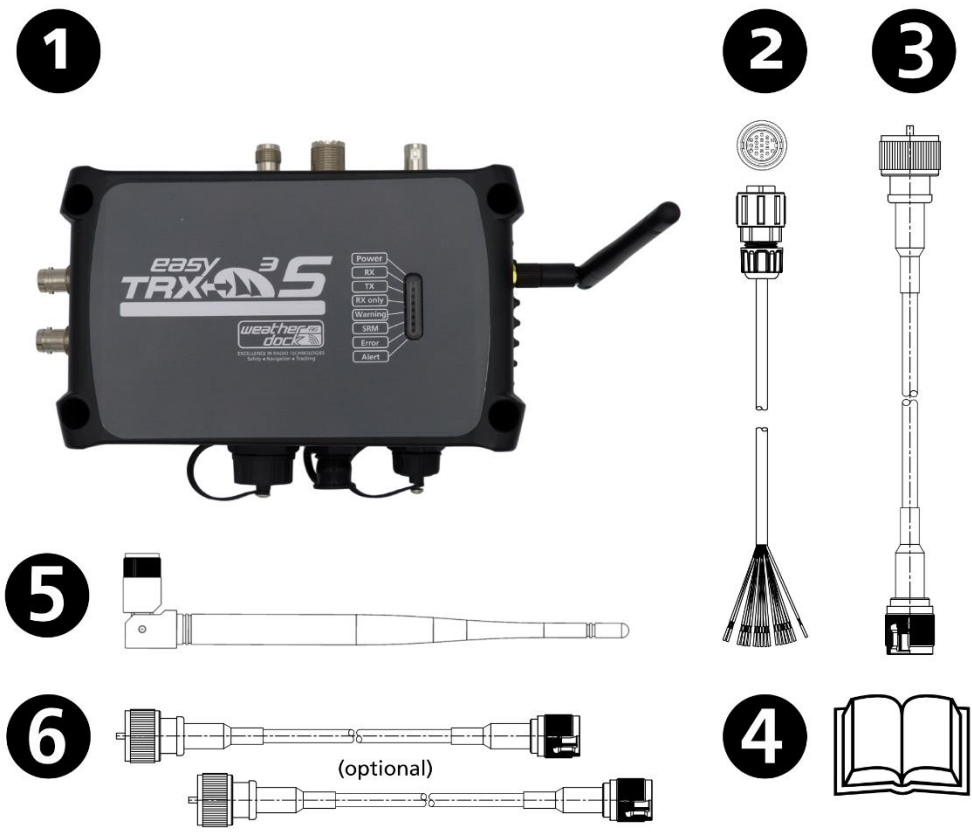

- AIS Class B easyTRX3S (exact product designation varies depending on the options added)
- Connection cable 10-pin (approx. 200cm)
- Connection cable easyTRX3S to VHF radio (approx. 100cm)
- Quick guide
- User manual online for download
- Programming software for Windows® PC and Apple® Mac
- 1x WiFi - Antenna
- DVB-T2 cable set (only included with DVB-T variant #A20023)

Figure 1 Scope of Delivery

5 Description easyTRX3S device

The easyTRX3S is a BSH approved AIS Class B SOTDMA transceiver, developed and manufactured by Weatherdock AG in Germany.

The easyTRX3S offers many advantages over other devices available on the market. For example, an integrated VHF radio antenna splitter, an integrated GNSS antenna and a BT-WiFi module are already included as standard.

The easyTRX3S also includes the ME SENSE RELAY functionality, which acts as the central control unit for ME SENSE yacht monitoring and thus enables smooth connection of the ME SENSE yacht monitoring sensors.

6 Outstanding features of the easyTRX3S

- ✓ **Integrated GPS antenna and processor (suitable for GRP and wooden hull boats)**
- ✓ **Integrated VHF antenna splitter (AIS and VHF radiotelephony via the same antenna)**
- ✓ **Integrated WiFi module**
- ✓ **Integrated ME SENSE RELAY (central control unit for ME SENSE yacht monitoring)**
- ✓ **USB port for programming via PC**
- ✓ **NMEA2000**
- ✓ **Status display via 8 LEDs**
- ✓ **CPA alarm possible independently of chart plotter**
- ✓ **Anchor alarm possible independently of chart plotter**
- ✓ **AIS MOB/SART alarm possible independently of chart plotter**

7 Connection options

7.1 Standard

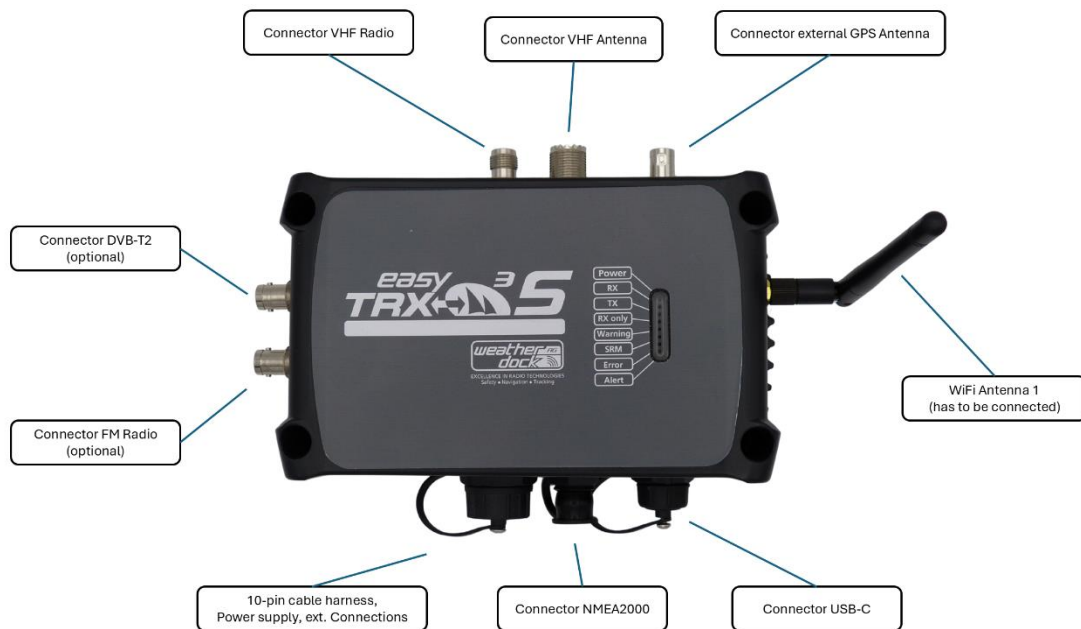

Figure 2 Connectors

- Integrated antenna splitter with connection for VHF antenna cable (SO239) including connection cable to VHF radiotelephone (TNC)
- External GPS antenna (BNC) if integrated GPS antenna cannot be used
- USB interface
- NMEA2000 output interface (Micro-C)

Options

Depending on the model variant, the following are also available as options

- DVB-T2 (BNC) - FM radio (BNC)
- LAN (RJ45)

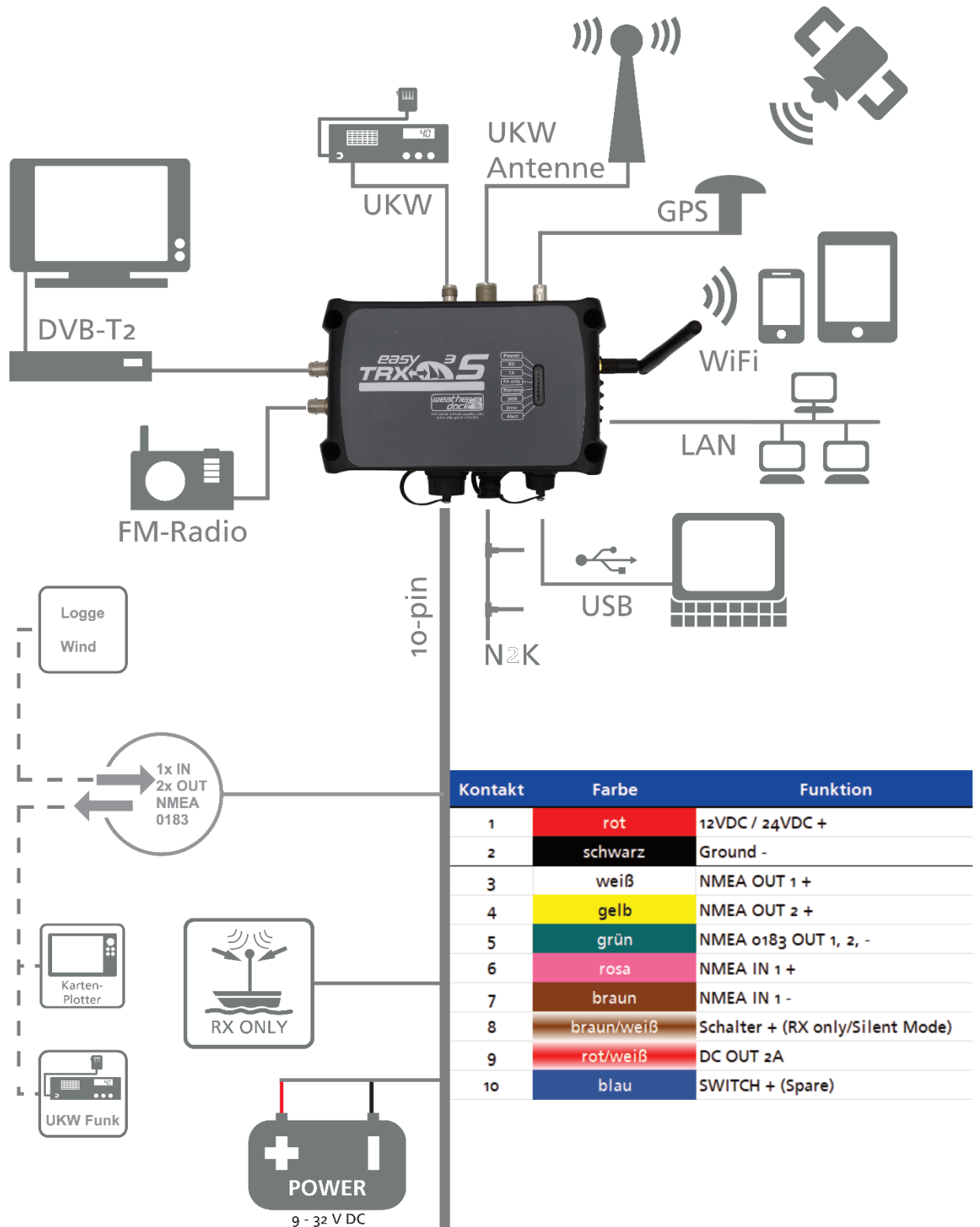

Figure 3 Connection options and cable colours

7.2 External Switches

7.2.1 RX only

Rocker switch

From the 10-pole wiring harness, connect the cables

- 08 / Brown-White / Switch+ (RX only) and
- 02 / black / Ground -

to the corresponding poles of the switch. You can now activate or deactivate the function according to your settings in the software. The software behaves accordingly.

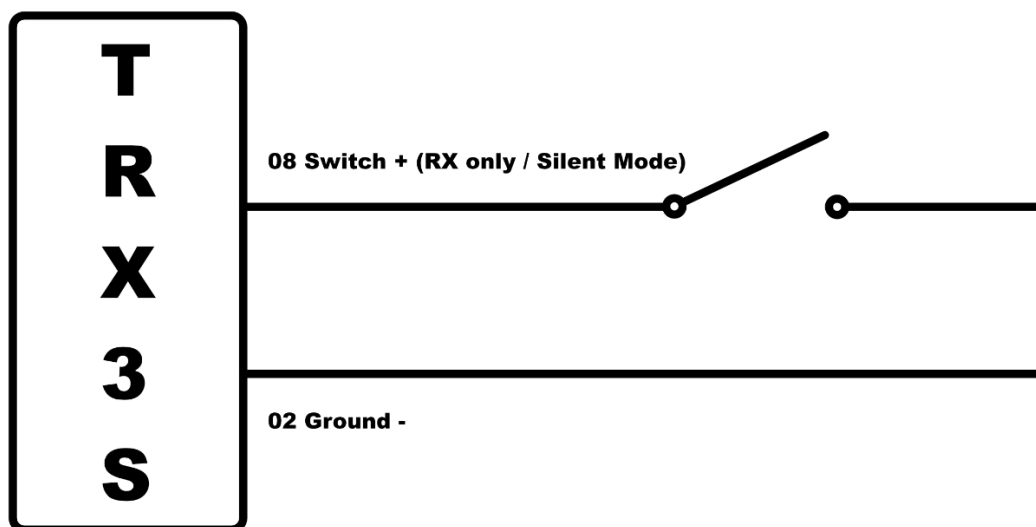

Figure 4 RX only

7.2.2 External signalling device

Connect the '09 / Red-White / DC OUT-' cable from the 10-pin wiring harness to the signalling device. As the easyTRX3 is already connected to the power supply '2 / Black / Ground-' and '1 / Red / 12V DC / 24V DC +', you only need to connect the '+ pole' of the signalling device to the power supply to close the circuit.

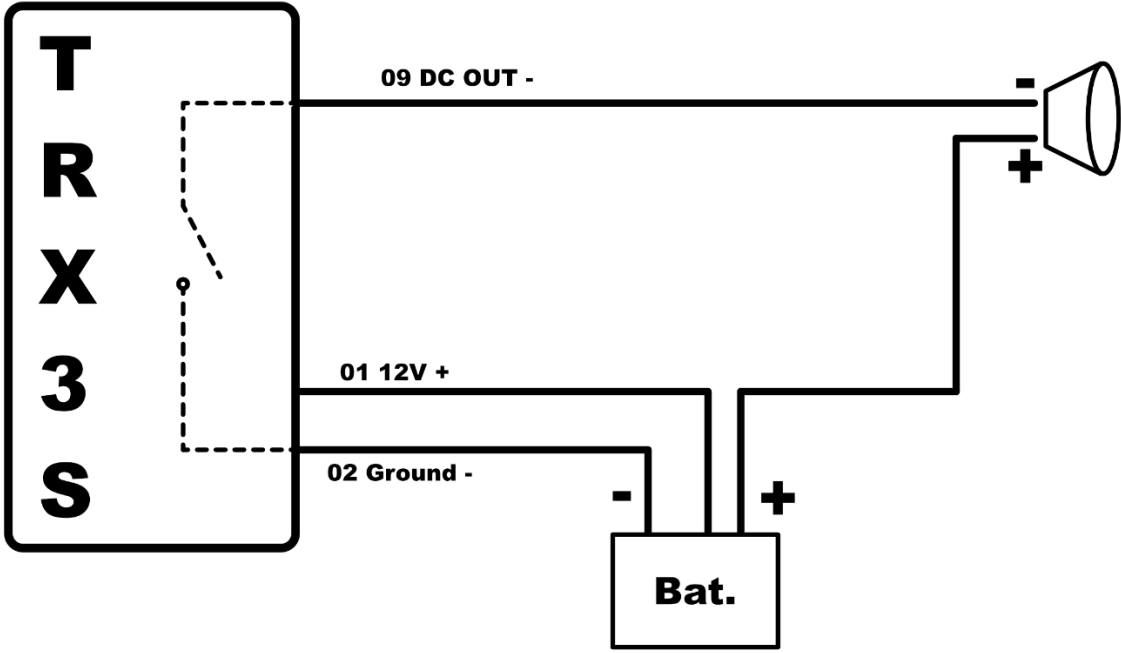

Figure 5 external signalling device

8 Device setup

With the basic settings, you create the elementary prerequisites for participating in the AIS system with your AIS Class B device, i.e. receiving the position data of other vessels and sending your own navigation data to the system.

8.1 Via USB Connection to PC/MAC/Laptop

To programme your ship-specific data, connect the easyTRX3S device to a PC/MAC or laptop via the USB cable.

The easyTRX3S can be configured and programmed via USB connection. You do not need a separate 12/24 V DC power supply. Power is supplied via the USB cable.

IMPORTANT NOTE

When powered via USB for programming, the easyTRX3S can neither send or receive AIS, nor GNSS and WiFi will work!

If you want to use the full range of features, the device needs a 12 or 24 volt power supply.



Figure 6 Programming Software

8.1.1 Connection

Click on 'Connection' to select and establish the connection with the easyTRX3S.

The connection via USB cable is already selected.

Now select the COM port to which the USB cable is connected.

If necessary, press the 'Refresh button' if you cannot see the appropriate COM port in the selection list.

Once the appropriate COM port has been selected, please press 'connect'.

The connection is now established.

You will see the received data in the lower field.

Continue the configuration of your AIS Class B Transceiver step by step and follow the instructions.

You can then proceed to program your device as described in detail in Chapter 8.1 ff.

8.2 WiFi connection and app use with a mobile device

The easyTRX3S can also be programmed from a mobile device (smartphone or tablet).

Download our free app 'easyTRX3 Manager' (Apple App Store® and Google Play Store®) and install it on your mobile device.



easyTRX3-Manager
(Englisch)



easyTRX3-Manager 1.0

Developed by



AIS Class B - SOTDMA

Connect	Not connec...	>
Interfaces		>
Diagnostics	---	>
Get Online-Map		>
Anchor Alarm	---	>
CPA Alarm	---	>
Sent Data		>
Static Data		>

WiFi-Connect

IP address or domain name

Host

Port

Connect

0, 0, 0, 0, 0, 0, 0, 0,

To use the 'easyTRX3 Manager' app, you must first set the Wi-Fi function of your mobile device to the easyTRX3 network.

The network name and password can be found on the label on the back of the easyTRX3.

After opening the app, you will see the start screen shown here.

In this case, the display is shown on an Apple iPhone®. The display on Android devices may vary slightly due to different operating systems. However, the basic functionality remains the same.

The start screen is the central point of contact from which you can access the individual settings.

Once you have entered the connection data or made changes to previous settings and confirmed them, you will always return to the start screen.

Tap on 'Not connected' to enter the connection data for the easyTRX3.

You will find the necessary information on the back of the device or on the side of the easyTRX3 packaging.

SSID
Password
IP-Adresse and
Port

Use this information to specify the connection to the easyTRX3 and indicate the exact path for accessing the easyTRX3 device.

After entering the data, tap the 'Connect' slider.

You can watch as the connection is established.

You will see data flowing into the lower windows.

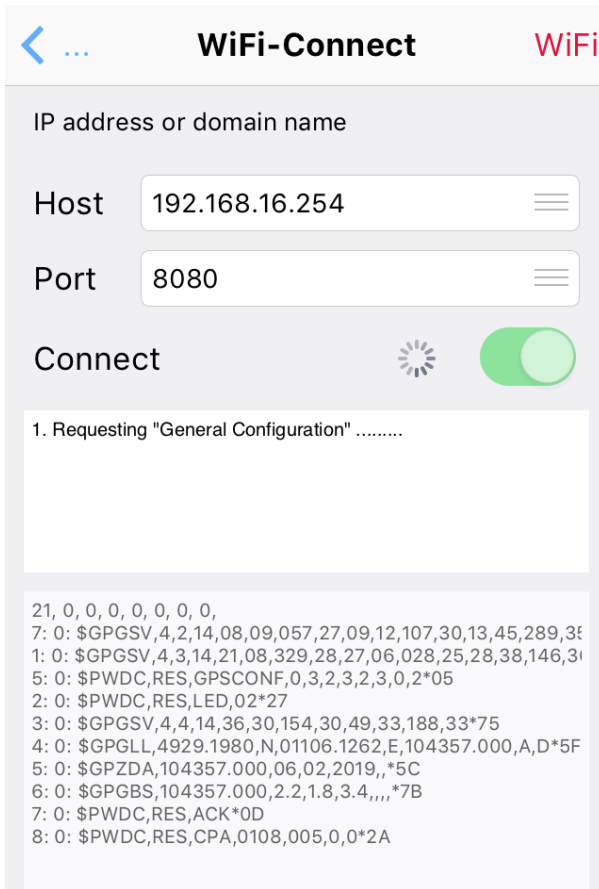

Once the connection is established, you can return to the start screen by clicking the arrow in the top left corner.

easyTRX3-Manager 1.0

Developed by



AIS Class B - SOTDMA

Connect	Connected	>
Interfaces		>
Diagnostics	All OK	>
Received Data		>
Anchor Alarm	Not active	>
CPA Alarm	Not active	>
Sent Data		>
Static Data		>

The easyTRX3 immediately performed a self-diagnosis and displays its current status as shown opposite.

In our example, everything is OK and the anchor alarm and CPA alarm are not activated.

Next, select 'Static Data' to program your vessel data into the easyTRX3.

To do this, you will also need your MMSI number, which you may already have from your VHF radio.

If you do not yet have an MMSI, you can apply for one from the Federal Network Agency.

You can download the relevant form in chapter 1.4 'Registration with the Federal Network Agency'.

Tap on 'Static Data' to make the next entries.

Static Data

MMSI

Name

Call Sign

Ship Type

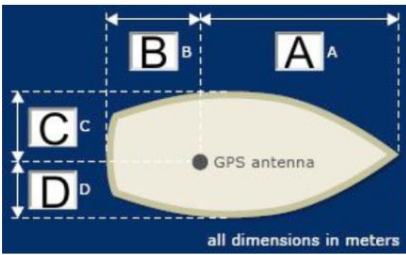

A

B

C

D

Here you can now enter your own ship data.

**MMSI
Name
Call sign)**

In addition, you can select the type of vessel that corresponds to your boat.

If you do not have a valid MMSI number, the easyTRX3 device cannot transmit to the AIS system.

The device is then automatically set to receive mode only (RX only).

Without a valid, registered MMSI number, no AIS data can be written to the internal memory.

As long as no MMSI number is entered, the easyTRX3 will always display a warning message that an MMSI number is missing. In addition, the yellow warning LED will indicate this status.

With the additional entries in fields A, B, C and D, you define the dimensions of your vessel and the position of the GPS antenna on board.

If you are using the integrated GPS antenna of the easyTRX3, the information must be provided in relation to the installation location of the easyTRX3.

Use the arrow at the top left to return to the start screen.

These were the basic settings that must be made in order to actively participate in the AIS system and send your own vessel data. You can now close the app.

To make further settings, such as advanced configuration of the easyTRX3, follow the descriptions below.

easyTRX3-Manager 1.0

Developed by



AIS Class B - SOTDMA

Connect	Connected	>
Interfaces		>
Diagnostics	All OK	>
Received Data		>
Anchor Alarm	Not active	>
CPA Alarm	Not active	>
Sent Data		>
Static Data		>

When you tap on 'Interfaces', you have the option of making further and more detailed settings to the configuration of the easyTRX3.

8.2.1 Functions via app

8.2.1.1 Transmitter

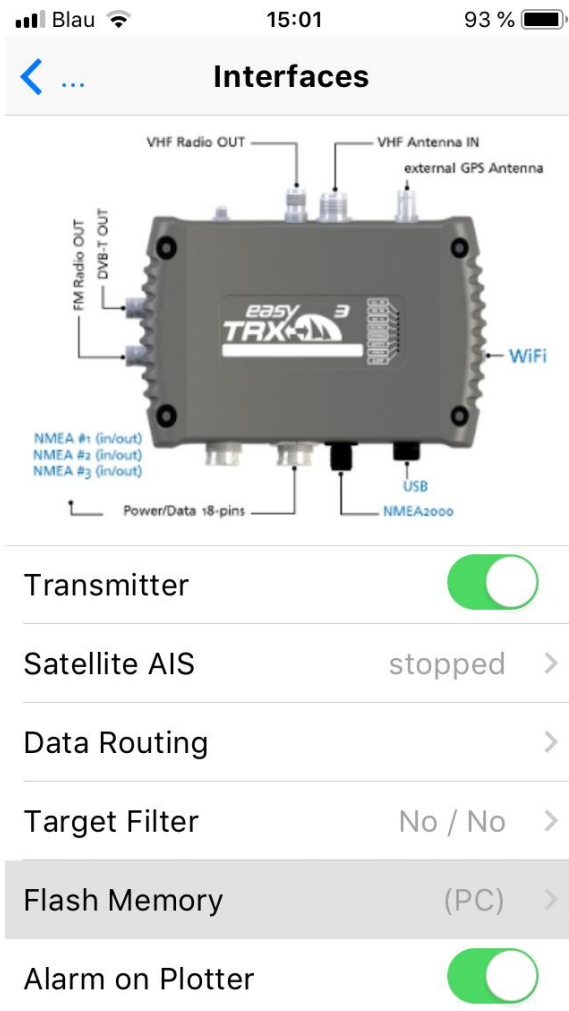

Use the slider button to set the easyTRX3 to receive-only mode (RX only). The device will now not send its own ship data to the AIS system.

A small window will open to confirm that programming was successful. You can close this window by clicking OK.

8.2.1.2 Long-Range AIS/Satellite AIS

< ... Satellite AIS

Satellite-AIS or Long-Range AIS transmits every 3 minutes a Position Report (Message 27) on special frequencies to satellites. This happens, when the easyTRX3 is out of range of an AIS Base Station (high sea). ATTENTION: Before activating Satellite-AIS, please refer to national regulations.

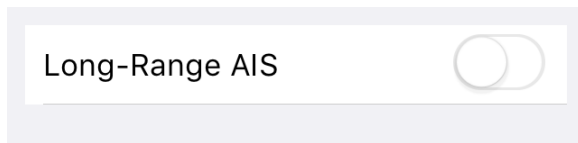

This function is deactivated in accordance with international regulations issued by the IMO when the device is delivered.

The long-range function is intended for use on the high seas, as you are outside the range of base stations.

When long-range AIS is activated, a position report is sent every 3 minutes on special frequencies to AIS satellites, which then forward it to coastal control centres. This means that the position of the ship is visible on land, even during a transatlantic voyage, for example.

If you return to the reception range of a base station while Long-Range AIS is activated, the coastal control centre may switch off Long-Range AIS. Please check the relevant national regulations.

If you leave the reception range of this base station again and had activated Long Range AIS before switching off, it will automatically reactivate itself.

This function is activated by tapping the button.

If users have not 'ordered' Long Range AIS from a satellite provider, the 'Long Range/Satellite Positions' will not be displayed on MarineTraffic, Vesseltracker or similar portals, i.e. there will be no costs incurred if the check mark is set.

A small window will open confirming that the programming was successful. You can close this window by tapping OK.

8.2.1.3 Data Routing/Data Configuration

Blau 14:05 85 %

Data Configuration

The easyTRX3 has got several data inputs and outputs (ports). Here you can configure each input and output. For each interface port you can select the data source, which shall be send out there.

NMEA-BAUDRATES

Port #1 (in/out)	38400
Port #2 (in/out)	38400
Port #3 (in/out)	4800

DATA AT NMEA#1-OUTPUT

AIS	<input checked="" type="checkbox"/>
GPS	<input checked="" type="checkbox"/>
NMEA-Input #1	<input checked="" type="checkbox"/>
NMEA-Input #2	<input type="checkbox"/>
NMEA-Input #3	<input checked="" type="checkbox"/>
USB-Input	<input type="checkbox"/>
WIFI-Input	<input type="checkbox"/>

This input mask is used to define which devices are connected as INPUT or OUTPUT to NMEA1, NMEA2, NMEA3, USB, WiFi and N2K.

NMEA-Baudrates

Here you can define the transmission rate at which the individual ports should operate.

You can choose between 4800 baud, 38400 baud or 115200 baud.

You can select different transmission speeds for the connections, e.g. NMEA1 IN/OUT with 4800 baud, NMEA2 and NMEA3 IN/OUT with 38400 baud.

Important to note:

The transmission rate must be the same for each connection, i.e. different devices can be used as IN and OUT, but the baud rate/transmission speed of these different devices must be the same.

Below, you can define for the different outputs which 'input data' is to be output to the connected devices at the respective ports. As an example:

NMEA Baudrates:

- NMEA1: 38400 Baud for IN/OUT
- NMEA2: 38400 Baud for IN/OUT
- NMEA3: 4800 Baud for IN/OUT

Routing:

GPS data were forwarded to

- NMEA1 – e.g. chart plotter
- NMEA2 – e.g. chart plotter
- NMEA3 – e.g. VHF radio
- N2K – board network
- USB – e.g. Laptop or PC
- WiFi – e.g. Tablet or other terminal device

AIS data were forwarded to

- NMEA1 – e.g. chart plotter
- NMEA2 – e.g. chart plotter
- N2K – board network
- USB – e.g. Laptop or PC
- WiFi – e.g. Tablet or other terminal device

INPUT data on NMEA3 (e.g. log or wind) were forwarded to

- NMEA1 – e.g. chart plotter
- NMEA2 – e.g. chart plotter
- USB – e.g. Laptop or PC

DATA AT NMEA#2-OUTPUT

AIS	<input checked="" type="checkbox"/>
GPS	<input checked="" type="checkbox"/>
NMEA-Input #1	<input type="checkbox"/>
NMEA-Input #2	<input type="checkbox"/>
NMEA-Input #3	<input checked="" type="checkbox"/>
USB-Input	<input type="checkbox"/>
WIFI-Input	<input type="checkbox"/>

- **WiFi – e.g. Tablet or other terminal device**

Once you found the best personal setting, please press on "Save".

DATA AT NMEA#3-OUTPUT

AIS	<input type="checkbox"/>
GPS	<input checked="" type="checkbox"/>
NMEA-Input #1	<input type="checkbox"/>
NMEA-Input #2	<input type="checkbox"/>
NMEA-Input #3	<input type="checkbox"/>
USB-Input	<input type="checkbox"/>
WIFI-Input	<input type="checkbox"/>

DATA AT USB-OUTPUT

AIS	<input checked="" type="checkbox"/>
GPS	<input checked="" type="checkbox"/>
NMEA-Input #1	<input type="checkbox"/>
NMEA-Input #2	<input type="checkbox"/>
NMEA-Input #3	<input checked="" type="checkbox"/>
WIFI-Input	<input type="checkbox"/>

DATA AT WIFI-OUTPUT	
AIS	✓
GPS	✓
NMEA-Input #1	
NMEA-Input #2	
NMEA-Input #3	✓
USB-Input	

DATA AT NMEA2000-OUTPUT	
AIS	✓
GPS	✓

8.2.1.4 Target Filtering

Transmitter	<input checked="" type="checkbox"/>
Satellite AIS	stopped >
Data Routing	>
Target Filter	No / No >
Flash Memory	(PC) >
Alarm on Plotter	<input checked="" type="checkbox"/>

There is also the option of defining and activating a 'target filter'.

This setting allows you to filter out AIS data that is outside your selected distance range from your display. This can be useful in areas with high traffic volumes in order to limit the view on your chartplotter to a reasonable extent.

Target Filtering

All NMEA-Ports

Range: Y1 =

USB, WiFi

Range: Y2 =

Help on Target-Filter >

The filter can be applied separately, i.e. different distances can be selected for USB and WiFi than for the NMEA connections. Only one of the two filters can be activated. Once you have set everything appropriately, click on the arrow at the top left.

Help

Range Filter:

The range filter has three tasks:

- Within 3 nm all targets (moving and non-moving) will be given to the selected output.
- Within the range between 3 nm and Y nm (programmable by the user) all moving targets are given to the selected output but all non-moving targets are removed.
- Outside the range of Y nm all targets (moving and non-moving) are hidden to the selected output.
- This target filter is only applied to the selected outputs. An unchecked output will deliver all targets!

8.2.1.5 Diagnostics

easyTRX3-Manager 1.0

Developed by

AIS Class B - SOTDMA

Interfaces >

Diagnostics All OK >

Received Data >

From the start screen, go to 'Diagnostics'.

The 'Diagnostics' function gives you a perfect overview of the proper functioning of the easyTRX3, or of any warning messages or error messages and why they occur.

Diagnostics

- All OK
- AIS RX
- AIS TX
- RX ONLY
- WARNING
- SAFETY
- ERROR
- ALERT

- [GPS Position...](#)
OK / 09 Sat. used
- [Transmitter](#)
OK
- [Receiver](#)
OK
- [Supply Voltage Idle](#)
14 V
- [Supply Voltage Tx](#)
12 V
- [Tx Forward Power](#)
412 - OK
- [Tx Reverse Power](#)
123 - OK
- [Temperature](#)
20°C
- [Error Info](#)
none
- [Warning Info](#)
none
- [Version Info](#)
1.0.13

All status LEDs of the device can be found here. The column to the right contains further brief information on the individual items.

GPS position
Information about the available satellite constellation is visualised here.
Tap on this field to display the graphic below.

GPS Diagnostic

Satellite ID	SNR / dB
04	32
05	41
08	33
13	36
15	34
21	36
27	16
28	32
36	32
39	39
41	41
31	31
36	36

3D-Fix HDOP = 1.0

Latitude = 49° 29.1972' N

Longitude = 011° 06.1260' E

SOG = 0.0 knots COG = -

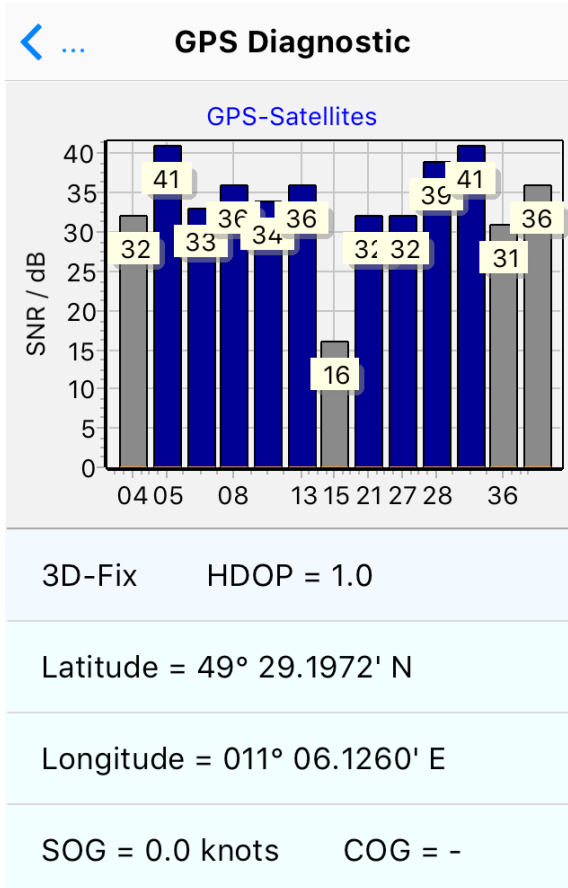

Here you can see information about your course and speed over ground, as well as your exact position with latitude and longitude coordinates. You can also see how many satellites are available for positioning and how many of them were actually used.

- **Course over Ground:**
Shows the current course of the ship over ground
- **Speed over Ground:**
Shows the current speed of the ship over ground
- **Latitude / Longitude:**
Displays the current position with longitude and latitude coordinates
- **Satellites in view/used:**
This indicates how many GPS satellites are being received and how many of them are being used for positioning.
- **HDOP:**
HDOP is a factor that determines the relative accuracy of a horizontal position. The smaller the DOP value, the better the geometry. The benchmark value is 2.5.
- The graph below shows a calculated HDOP value of 1.0, which is very good.

Diagnostics

- All OK
- AIS RX
- AIS TX
- RX ONLY
- WARNING
- SAFETY
- ERROR
- ALERT

- [GPS Position...](#)
OK / 09 Sat. used
- [Transmitter](#)
OK
- [Receiver](#)
OK
- [Supply Voltage Idle](#)
14 V
- [Supply Voltage Tx](#)
12 V
- [Tx Forward Power](#)
412 - OK
- [Tx Reverse Power](#)
123 - OK
- [Temperature](#)
20°C
- [Error Info](#)
none
- [Warning Info](#)
none
- [Version Info](#)
1.0.13

Transmitter

Indicates whether everything is OK for the transmission of your own AIS data.

Receiver

Indicates whether everything is OK for receiving general AIS data.

Supply Voltage "Idle" / Supply Voltage "TX"

This is the voltage value during transmission. Here, the easyTRX3 device briefly draws approx. 2 A of current from the on-board power supply. If the supply wires are too thin and relatively long, the voltage can drop significantly below the 'idle' value (rest value), which can lead to reduced transmission power. It may be necessary to select a thicker cable or check all contact connections.

TX Forward Power / TX Reverse Power

'TX Forward Power' and 'TX Reverse Power' are set to OK if the connected FM antenna is working properly. If the antenna has a short circuit or the antenna cable is broken, 'Error' is displayed here.

Error message{XE "Error message" } / Warning message

If there is a warning or error, this is indicated by the LED. In addition, the error is briefly defined in the list. If this happens, please use the programming tool stored in the internal memory for further analysis (see also Chapter 13).

Version Info

It is a violation of rules of national authorities to use this application to program or delete an MMSI that has not properly assigned to the end user, or to otherwise program any inaccurate data into a device. Factory reset must be carried out by a Weatherdock Dealer. Apply for a one-time PIN by e-mailing the key to "support@weatherdock.de".

Model: easyTRX3, A20000
Production Date: 2018-08-13
Hardware Version: 2
Firmware Version: 1.0.13
Vendor ID: WDC@@@
Serial: 000000000
BSH/4542/001/4323246/18

Factory-Reset (Key / PIN):

Key [Get new Key](#)

Enter PIN [Do Factory-Reset](#)

Version
 Here you can find information about the current firmware version.
You can also reset the device to its factory settings here.

easyTRX3-Manager 1.0

Developed by



AIS Class B - SOTDMA

- Diagnostics All OK ✓
- Received Data >
- Anchor Alarm Not active ✓

Received Data
 Under 'Received Data', you will find an overview list of all ships whose AIS data has been received.

By clicking on a list entry, you will see all information about this object at a glance.

Tap on Map to display the objects in their relative position to your ship. If you have a mobile data connection, Google Maps® can also be displayed as a layer.

If, for example, an activated AIS distress beacon is received, this position is not displayed as a ship symbol, but as an 'X' with a circle.

Received Data 

AIS Objects found: 1 [Scroll LIST to show additional Ships]

~970236999 0.1 nm >

▲
nm [Map](#)

Ship-Information 

~970236999 

MMSI: 970236999
 Call-Sign:
 Destination:
 ETA:
 Type: Ship with no information
 Size: x m
 Draught: -
 Status: unknown

Latitude 49° 29.1977' N	SOG 0.0 knots
Longitude 011° 06.1248' E	COG -
Distance 0.1 nm	TH -
Last Report 4:10	Bearing 6°

[Map](#)

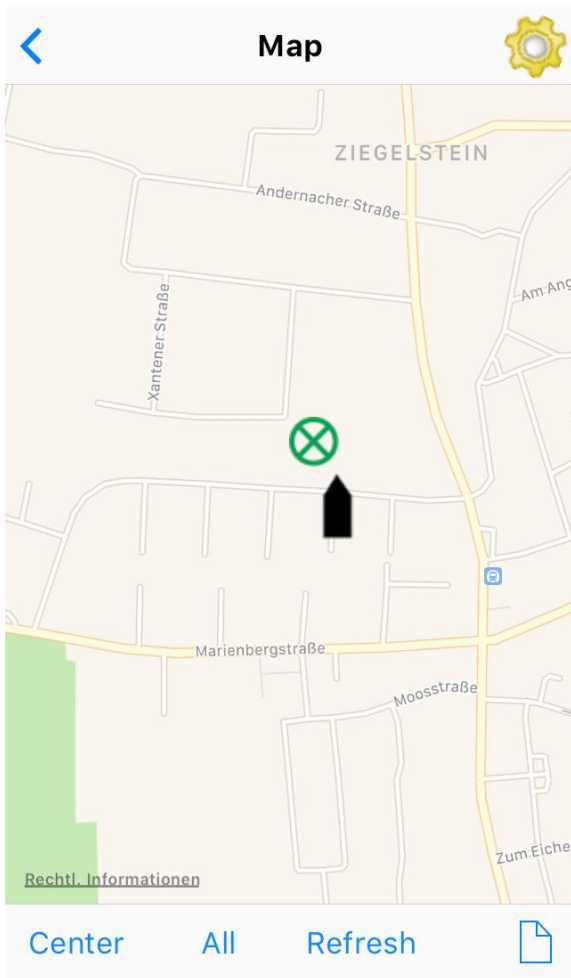

8.2.1.6 Anchor Alert

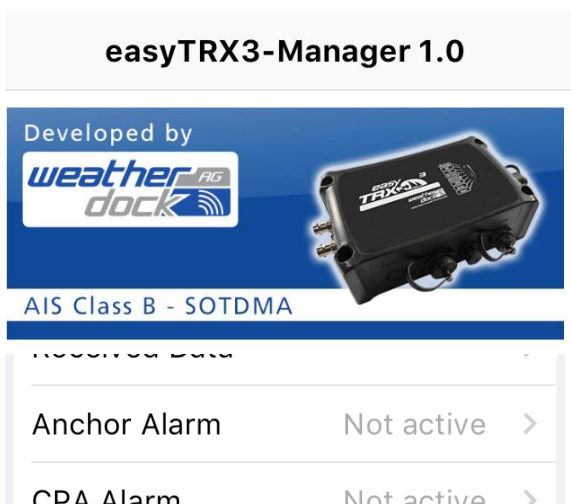

This function acts as a kind of anchor watch. It is deactivated in the factory default setting.

You can define a distance value as the radius around your anchor position. This value depends on the swaying of your ship in the wind and current at anchor and the length of the given anchor chain or anchor line.

Anchor Alarm

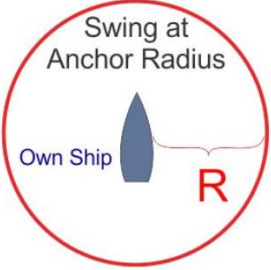

Swing at Anchor Radius

Own Ship

R

Swing Radius [m] < 100 >

[ft] 328

Anchor Alarm

Help on Anchor Alarm >

Within this circular arc, the natural movement of the ship must be taken into account and no alarm may be triggered.

Like the CPA alarm, the anchor alarm can be used with the easyTRX3 when the chart plotter is switched off. In the event of an alarm, the alarm can be triggered via a connected signal device (e.g. horn).

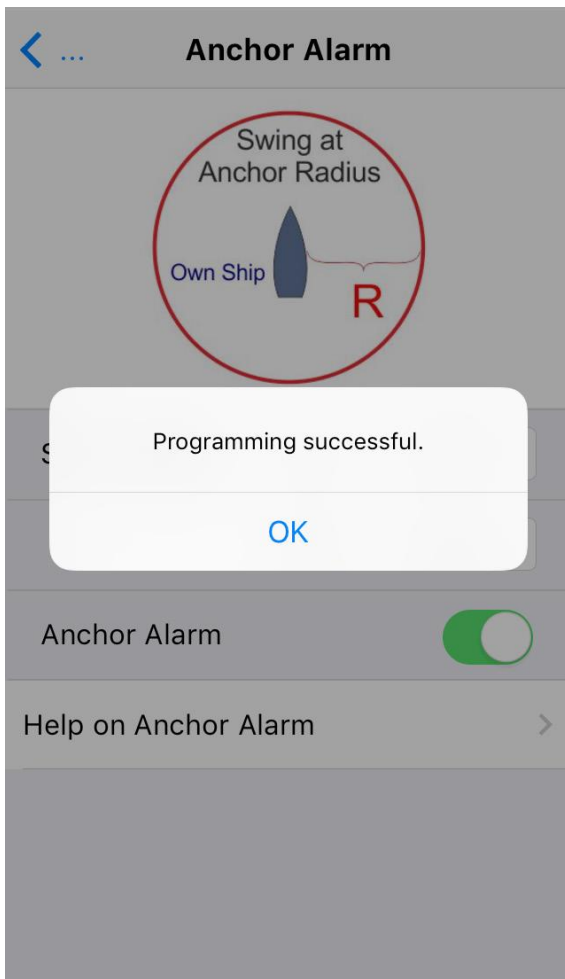

A small window will open to confirm that the programming was successful. You can close this window by clicking OK.

Use the arrow to return to the previous overview.



Attention:
 =====
 Anchor-Alarm can only be turned on with valid GPS-Fix! Do not set the radius to a low value. The GPS accuracy may be more than 10-30 meters, depending on satellite constellation or weather conditions. This would cause false alarms.
 In case of no GPS position fix no Alarm will occur!!
 When you turn on the Anchor-Alarm (by programming or switch), the actual GPS position is used as anchor position.

8.2.1.7 CPA Alert - Collision warning



CPA alarm is a so-called collision alarm (closest point of approach). With this setting, you define an imaginary zone around your own ship using a time value and a distance value.

Except for Weatherdock AIS Class B devices, it is necessary to make these settings on the chartplotter itself. However, it is essential to keep the chartplotter, with its high power consumption, in operation at all times, as most other AIS Class B devices only receive the AIS data and simply forward it to the chartplotter for further data interpretation. On longer voyages, however, this can lead to problems with power management.

CPA Alarm

Closest Point of Approach (CPA)

Time to CPA

Own Ship

Target

CPA

Time-to-CPA [min] < 5 >

CPA [meters] < 2000,16 >

CPA Alarm

Help on CPA >

The big advantage of Weatherdock's easyTRX3 is that the device itself interprets the AIS data. If the easyTRX3 receives and interprets AIS data that is within your defined zone and a collision is imminent, an alarm can be triggered via a connected signal device (e.g. horn). You can now add the chart plotter as a display medium and switch it on. The current danger situation is shown on the screen.

Enter your desired distance and time values individually in the text fields provided and activate the CPA alarm with a click.

You will now see that the alarm is active and receive a confirmation window, which you can close by clicking 'OK'.

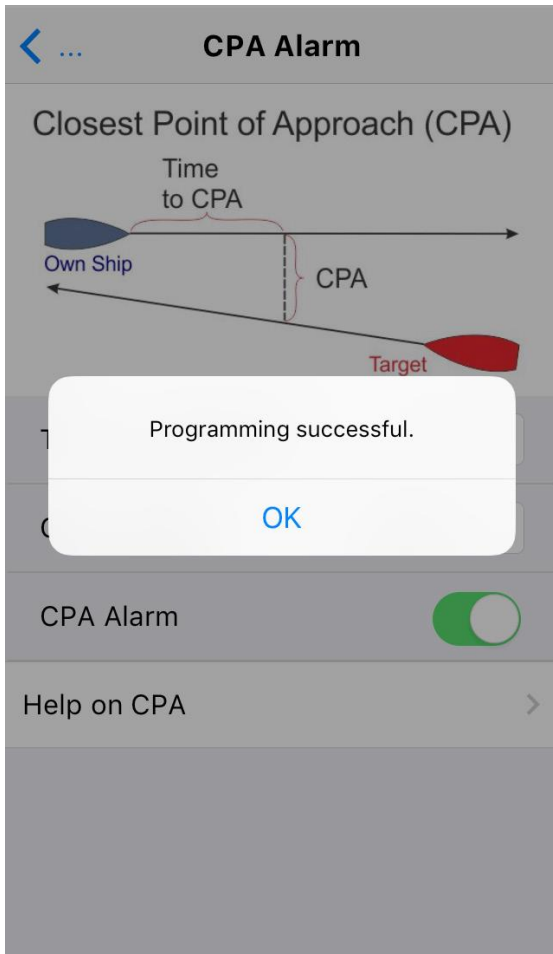

Description:

=====

Closest Point of Approach is closest distance two vessels will come to each other based on their current course and speed calculated by AIS.

Time-to-CPA [min]:

=====

For setting the minutes how far the other ship at least should be before the CPA Alarm goes off.

CPA [meters]:

=====

For setting the meters how far the other ship at least should be before the CPA Alarm goes off.

Resolution is 1/100 nautical mile (= 18.52 m). You can choose from 18.52 m to 2000.16 m.

8.2.1.8 Sent Data

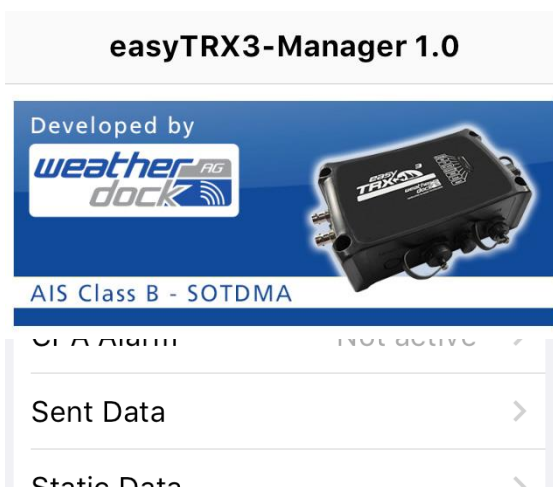

Sent Data

Under 'Sent Data', you will find a complete overview of all information that the easyTRX3 transmits to the AIS system for your ship's position.

You will see the AIS position report with additional information such as course and speed over ground.

You will also see the so-called 'static data' that is sent to the AIS system for your ship.

Sent Data	
AIS-POSITION REPORT	
INTERVALS: 3 MIN, 30 S, 15 S, 5 S DEPENDING ON SPEED	
MMSI	211002010
Latitude	49° 29.1976' N
Longitude	011° 06.1258' E
Course over ground	360.0 deg T
Speed over ground	0.0 knots
AIS-Channel	B
Last Transmission	2:54

Sent Data	
AIS-STATIC DATA (EVERY 6 MINUTES)	
MMSI	211002010
Ship's Name	WD MK
Type of ship	Sailing Vessel
Vendor ID	WDCD
Call Sign	WD MK
Dimension A	8 m
Dimension B	8 m
Dimension C	2 m
Dimension D	2 m
AIS-Channel	B

8.3 ME SENSE

In addition to AIS, the easyTRX3S is also suitable for use with marine IoT. The device has an integrated ME SENSE functionality. This allows different sensor values to be received via a Bluetooth connection to the sensors and transmitted to your home via a WiFi connection to the ME SENSE app.

8.3.1 ME SENSE App

Download the free app from your preferred app store and launch it on your smartphone or tablet.



After opening your app store, enter 'weatherdock ag' as the search term. Scroll down until you see the ME SENSE app with this icon:



8.3.2 Basis-Version App

In the basic version of the app without a subscription, the battery voltage tester (the easyTRX3S connected to the vehicle electrical system) and any other sensor can be used without any time restrictions and displayed with the current values.

There are no additional fees for this configuration.

8.3.3 Abo-Version / in-app purchases

If you want to use additional sensors for monitoring and display on your smartphone, you will need the app subscription. Here, up to 20 sensors and up to 10 switches (on/off) can be used, managed and displayed simultaneously. The selection and number of sensors can be adapted to your on-board requirements.

The app recognises when you need a subscription and automatically redirects you to the purchase process.

The subscription has a term of 12 months. After the term expires, the measured values are no longer displayed in the tiles and the functionality returns to that of the basic version of the app. The subscription price is €29.99.

8.3.4 App installation ME SENSE

After launching the app, you will see this screen

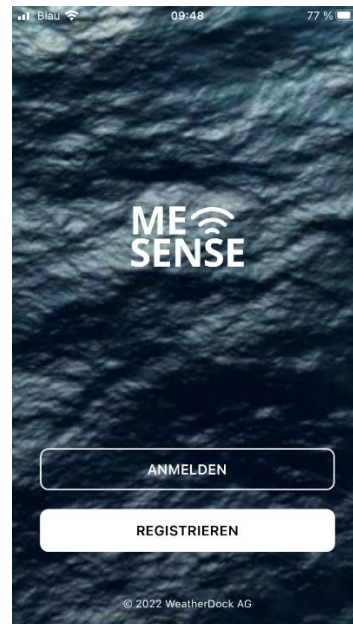

Click on 'Register' to create your user profile.

Enter your email address and a password. Fields marked with an asterisk (*) are mandatory and must be filled in.

Once you click on 'Register', a 6-digit verification code will be sent to you by email.

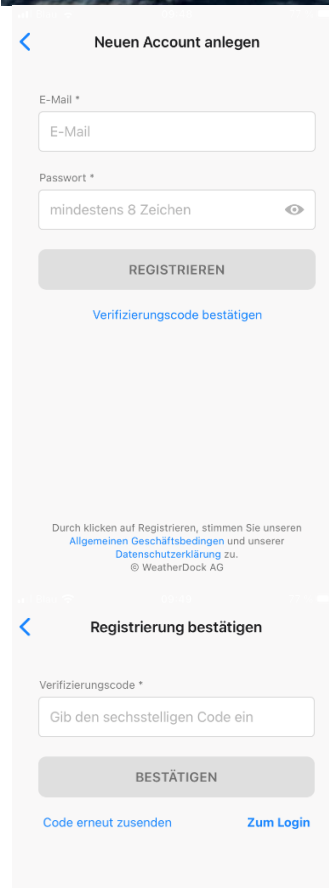

Enter the verification code you received by email and click 'Register' again.

After successfully registering, you will be asked to add a boat to your profile.

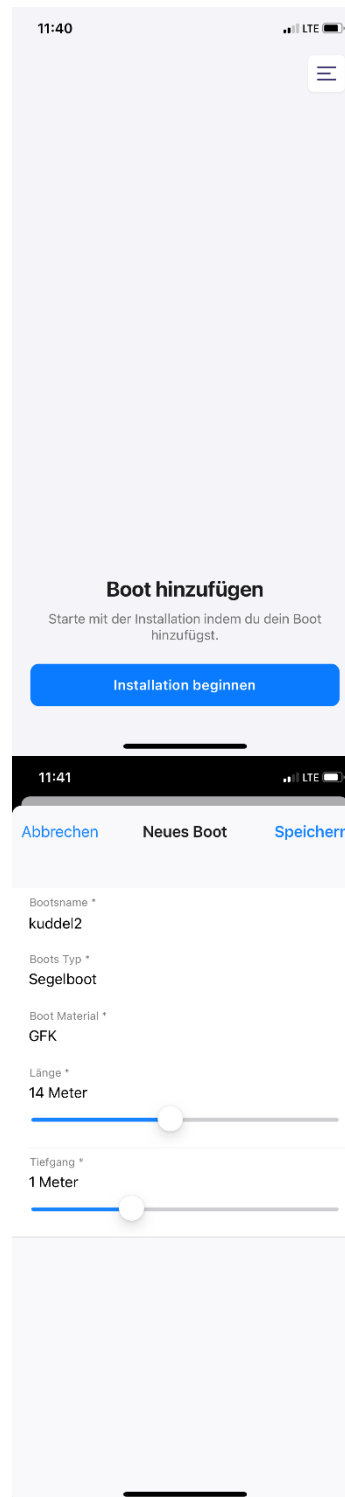

Configure your boat with the relevant details regarding

- name,
- boat type,
- material,
- length
- draught

Then press 'Save' and you will be automatically redirected

In the next step, you will be asked to integrate the ME SENSE RELAY into the app

Tap on 'Configure ME SENSE RELAY'

To scan the QR code on the ME SENSE RELAY device, you must first grant access rights for the camera and Bluetooth.

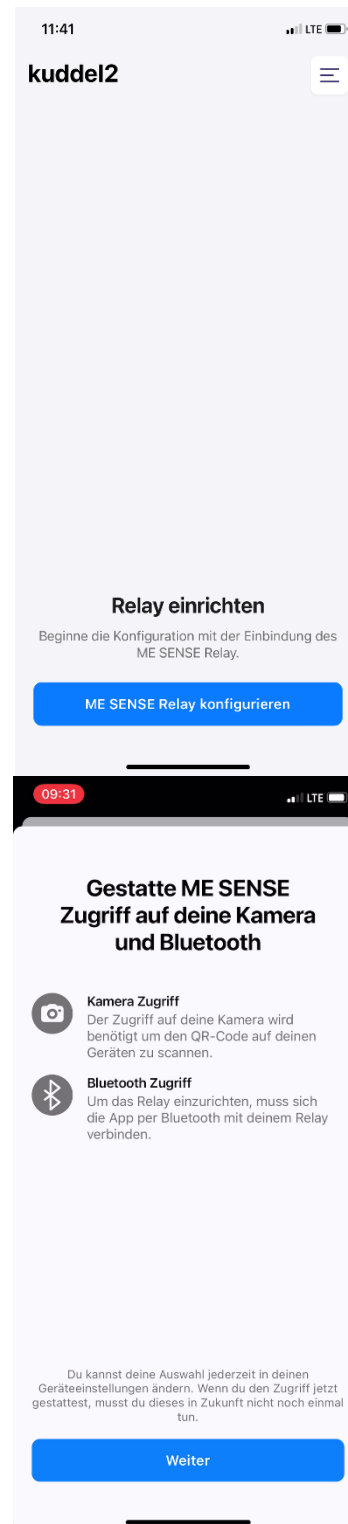

The next step is to run a query to eliminate any possible errors in advance.

Then tap on 'Continue'.

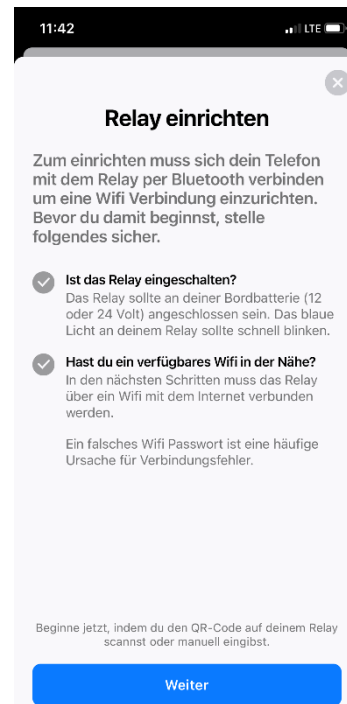

The dialogue window opens and you can conveniently scan the QR code displayed on the side of the easyTRX3S device with the camera of your mobile device.

Alternatively, you can also enter the configuration code manually. Please ensure that you enter it correctly, including upper and lower case letters. You will find this code directly below the QR code.



You will see this confirmation that the ME SENSE RELAY has been successfully read in the form of the easyTRX3S

Now add the Wi-Fi network you want to use by clicking on 'Add Wi-Fi'.

This allows you to use up to 8 different Wi-Fi networks for different marinas. The ME SENSE RELAY in the TRX3S automatically detects the network with the strongest signal and connects to it.

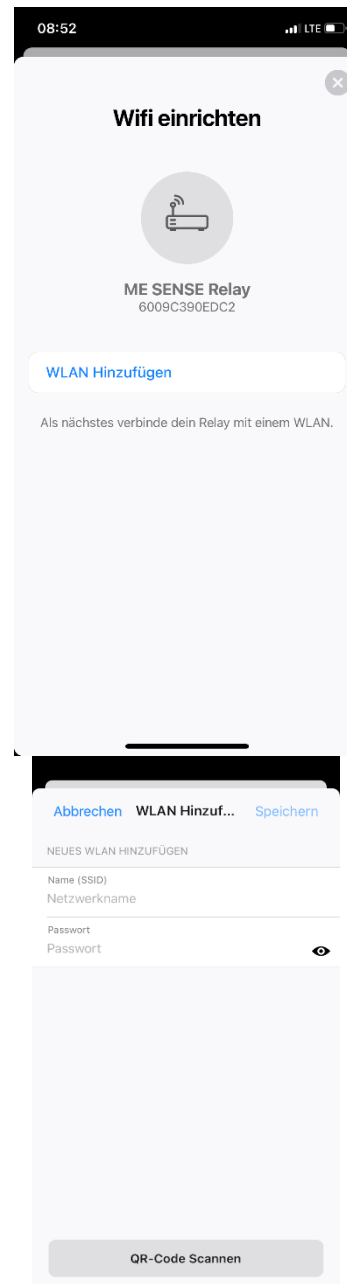

Depending on the form in which you have received the access data for the Wi-Fi network, you can enter the data manually or scan a QR code if necessary.

Make sure you enter the data correctly, including upper and lower case letters.

Do not use open networks without a password; only use encrypted Wi-Fi networks for which you have the network name (SSID) and password.

Alternatively, use an LTE hotspot and generate your own access to upload the ME SENSE sensor data to the data cloud.

You will see that your Wi-Fi network has been successfully found.

To complete the setup of the Wi-Fi network with the ME SENSE RELAY, please tap on 'Connect relay to Wi-Fi'.

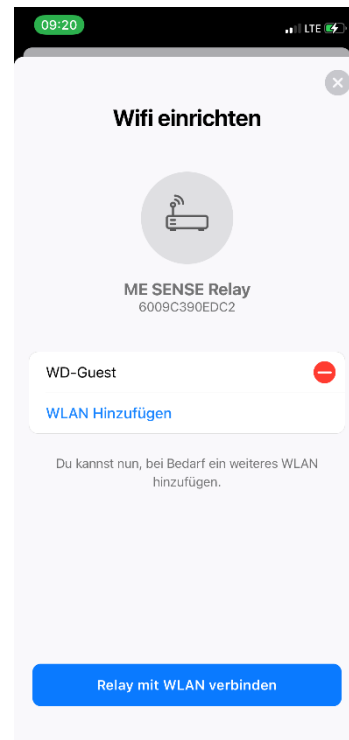

You can follow how the connection is established and maintained.

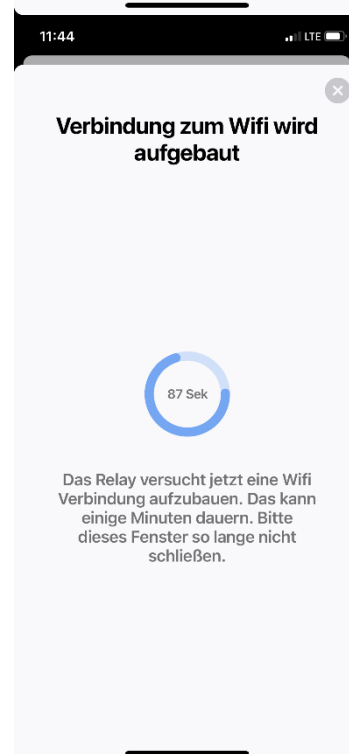

The ME SENSE RELAY is now successfully connected to the Wi-Fi network.

To check, you can observe the blue LED on the ME SENSE RELAY.

It lights up for 1 second every 60 seconds.

Confirm with 'OK'.

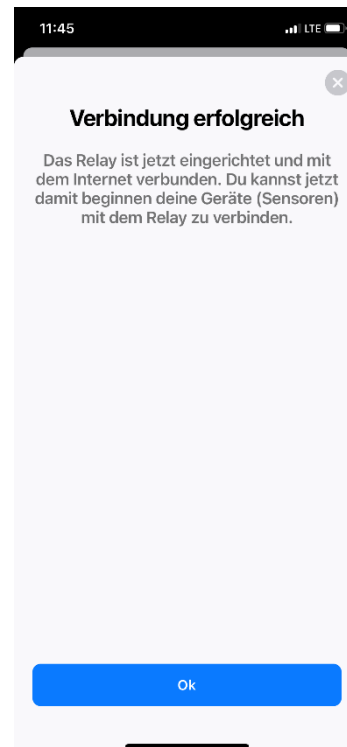

You will automatically be taken to the app's main view.

Here, the individual sensors are displayed in tile form.

Since the easyTRX3S with the integrated ME SENSE RELAY also functions as a battery voltage sensor, you will already see an initial sensor value.

Now you can begin integrating your ME SENSE sensors into the system.

Click on 'Add device'.

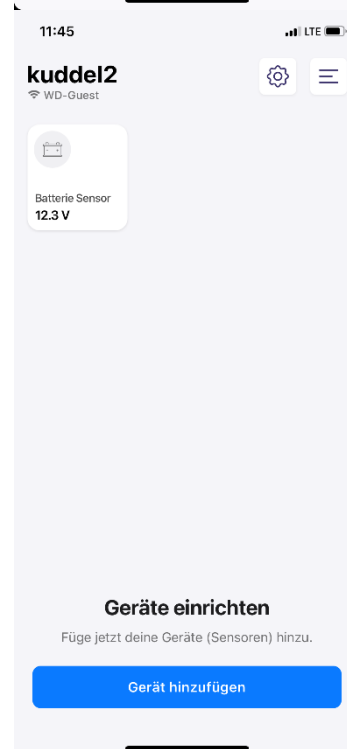

Before scanning the sensor's QR code, please remove the battery protector first. To do this, simply pull out the red strip.



This message appears for security reasons, to double-check that everything is OK and to avoid error messages.

Please tap on 'Continue'.

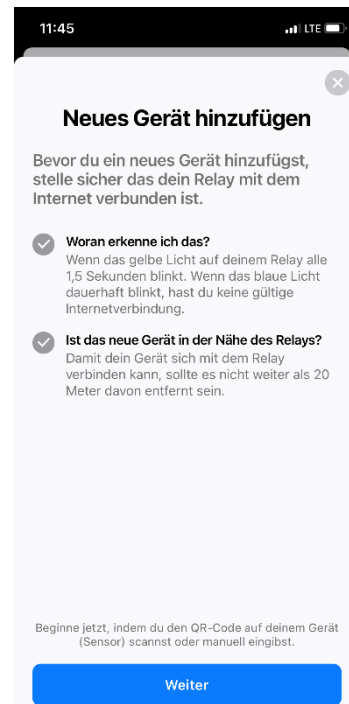

The dialogue window opens and you can conveniently scan the QR code displayed on the device with the camera of your mobile device.

Alternatively, you can also enter the configuration code manually. Please ensure that you enter it correctly, including upper and lower case letters.

You will find this immediately below the QR code.



To help you distinguish between the different sensors, you can enter a unique name for each sensor, which will then be displayed in the app. These names can be changed at any time .

To do this, tap in the input field.



You can enter the new sensor name using the keyboard.

Finally, press the 'Enter' key on your keyboard to return to the display.

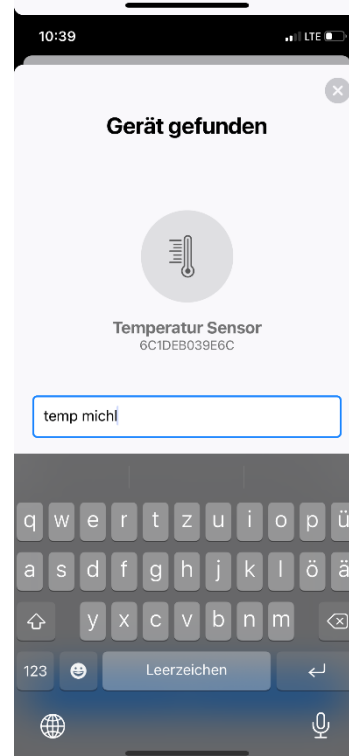

You can confirm your entry by clicking 'OK'.

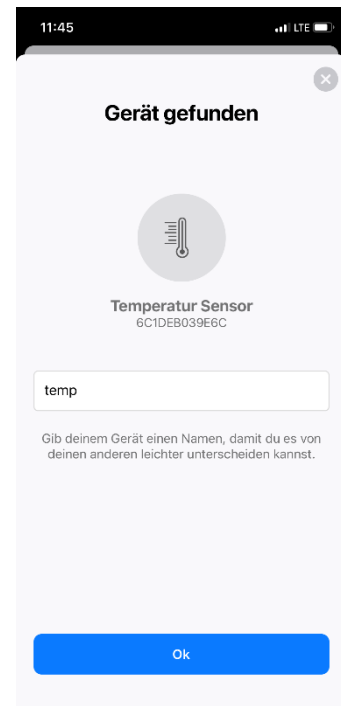

You will see a message indicating that the scanned sensor has been read correctly and is ready to connect to the ME SENSE RELAY.

The sensor tile will only appear in the overview once this connection has been established.

Tap on 'Connect this device'.

Here, you also have the option of scanning additional sensors directly and connecting them to the ME SENSE RELAY at the same time.

To ensure that the sensors are installed correctly, we recommend that you proceed step by step and connect each sensor separately one after the other.

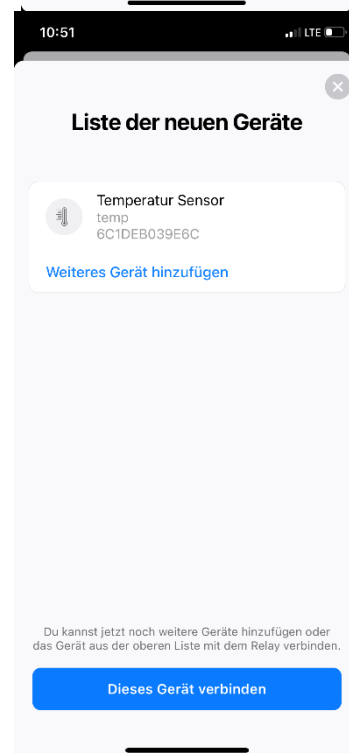

You can once again witness in real time how the connection is established.

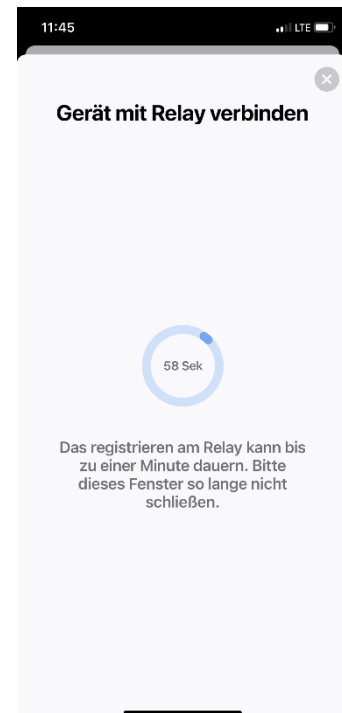

The sensor has been successfully connected to the ME SENSE RELAY.

It may take a while before the sensor data is received for the first time.

Tap 'OK'. You will be taken back to the main view of the ME SENSE app.

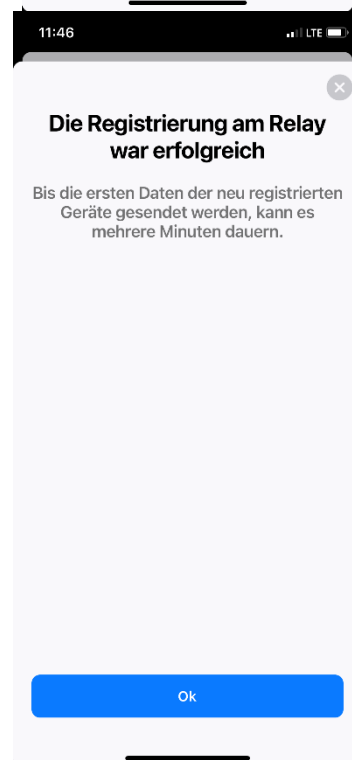

As soon as the sensor data is received, you will see the current value, in this case the current temperature.

The tile also shows the battery status of the sensor and the connection quality.

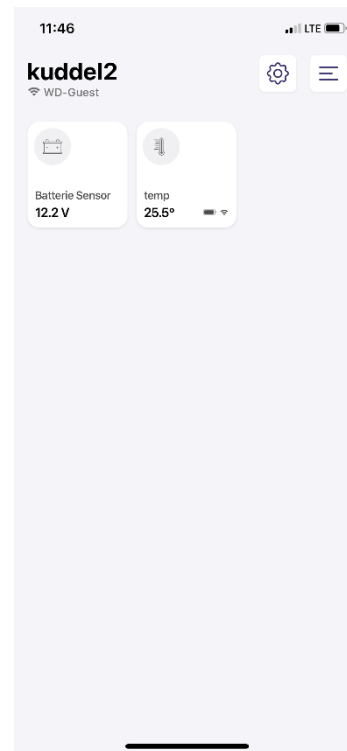

For each additional ME SENSE sensor that you wish to integrate into the system at a later date, simply repeat the steps described above.

9 Integrated Modular Design

9.1 IS - integrated FM antenna splitter

The standard integrated VHF antenna splitter allows you to use a VHF antenna already installed for VHF radiotelephony for AIS as well. This avoids the need for an additional new antenna installation.

The module controls the parallel operation of VHF radiotelephony and AIS (reception and transmission), with radiotelephony taking priority. The received signals are first pre-amplified to avoid a loss in signal strength due to disconnection.

9.2 IGPS - integrated GPS Antenna

The integrated GPS receiver of the TRX3S can be used on GRP and wooden hull boats, making the additional installation of a GPS antenna on deck superfluous. However, if you have a steel hull or aluminium boat, you will need to install an external GPS antenna on deck.

9.3 N2K - integrated NMEA2000 Module

The NMEA2000 interface is designed to feed the received AIS and GPS data into the NMEA2000 network on board.

Currently, only output to the on-board network is possible.

PGN	Description
059392	ISO Acknowledgement
060928	ISO Address Claim
059904	ISO Request
060160	ISO Transport Data Transfer
060416	ISO Transport Connection Management
126208	NMEA Request/Command/Acknowledge Group Function
126464	PGN List
126992	System Time
126996	Product Information
129025	Position Rapid update
129026	COG & SOG Rapid update
129038	AIS Class A Position Report
129039	AIS Class B Position Report
129040	AIS Class B Extended Position Report
129539	GNSS DOPs
129540	GNSS Sats in View
129794	AIS Class A Static and Voyage Related Data
129795	AIS Addressed Binary Message
129797	AIS Binary Broadcast Message
129798	AIS SAR Aircraft Position Report
129801	AIS Addressed Safety Related Message
129802	AIS Safety Related Broadcast Message
129809	AIS Class B "CS" Static Data Report, Part A
129810	AIS Class B "CS" Static Data Report, Part B

Figure 7 NMEA2000 Messages

9.4 WiFi - integrated WiFi Modul

All data that is fed into the easyTRX3S (AIS, GPS and NMEA0183) is transmitted 1:1 to connected mobile devices such as smartphones, tablets or laptops in the corresponding product variant via WiFi radio connection.

The WiFi module used is designed so that up to 10 mobile devices can be connected to the easyTRX3S at the same time.

10 Optional Modular Design

10.1 DVBT - integrated antenna splitter for DVB-T2 and FM radio signals (optional)

The optional 'DVBT' product variant includes a frequency crossover (with pre-amplification), which enables you to pick up DVB-T2 and VHF radio signals - in addition to radiotelephony and AIS - via your marine band antenna.

No further settings or adjustments are necessary.

A corresponding DVB-T2 receiver must be connected to the 'DVB-T' socket; an FM radio can simply be connected to the corresponding 'FM radio' socket. Reception is also via the VHF antenna that you already use for radiotelephony and AIS.

11 On-board installation of the easyTRX3S

The easyTRX3S must be mounted above the waterline when installed below deck in order to be able to use the internal GPS antenna. If necessary, consider the inclined position of a sailing ship when travelling upwind.

On-deck mounting is also possible with the easyTRX3S due to its IP67 protection classification.

Please keep a safe distance of at least 60 cm from other technical devices and/or compass when mounting.

12 Technical Data

Description	Value
General	
Dimensions	195mm * 135mm * 60mm (L*B*H)
Weight	±500 Gramm
Operating temperature range	-15°C bis 55°C
Storage temperature range	-20°C bis 75°C
Safety distance Compas	mind. 40cm
Power Specification	
On-board voltage	12V DC / 24V DC
Operating voltage range	9,6 bis 31,2V DC
Power consumption	2,9W bei 12V DC
Power input	3A (Senden), -240mA (Stand.) bei 12V DC
GNSS Specification	
	72 Channel GNSS Receiver
GPS/GNSS Reveiver (internally)	# GPS
	# Glonass
	# Gallileo
External Connections	

Interfaces	1x NMEA0183 IN 2x NMEA0183 OUT NMEA2000 USB-C 10-pin plug
Connectors	NMEA2000 socket external GPS Antenna (BNC) FM antenna connection (TNC) VHF radio connection (SO239)
Data type NMEA output	VDM
Options	DVB-T2/FM
AIS Specification	
Transmitter	1 Transmitter (AIS1/AIS2)
Receiver	2 Receiver (AIS1/AIS2) DSC (AIS Channel Management) Marine Band: 156,025MHz - 162,025MHz
Frequencies	AIS1: 161,975MHz AIS2: 162,025MHz
Transmission Power	5Watt / 1Watt (50Ohm) (switchable by coastal station)
Channel width / grid	25kHz
Modulation	GMSK (AIS, TX und RX) FSK (DSC, RX only)
Transmission rate	9600b/s 1200b/s
Reception sensitivity	-114dBm 25kHz (<20% PER)
Second channel suppression	10dB
Adjacent channel suppression	70dB
Intermodulation distance	65dB
Blocking	84dB
Certifications	

AIS Standards

IEC 62287-2:2017

Environmental

IEC 60945:2002 + Corr.1:2018

GPS Performance

IEC 61108-1:2003

Product Safety

EN 60950-1:2006

BSH Approval

ITU-R M.1371-5

BSH/4542/001/4323246/18

Figure 8 Technical Data

13 Possible connection diagram

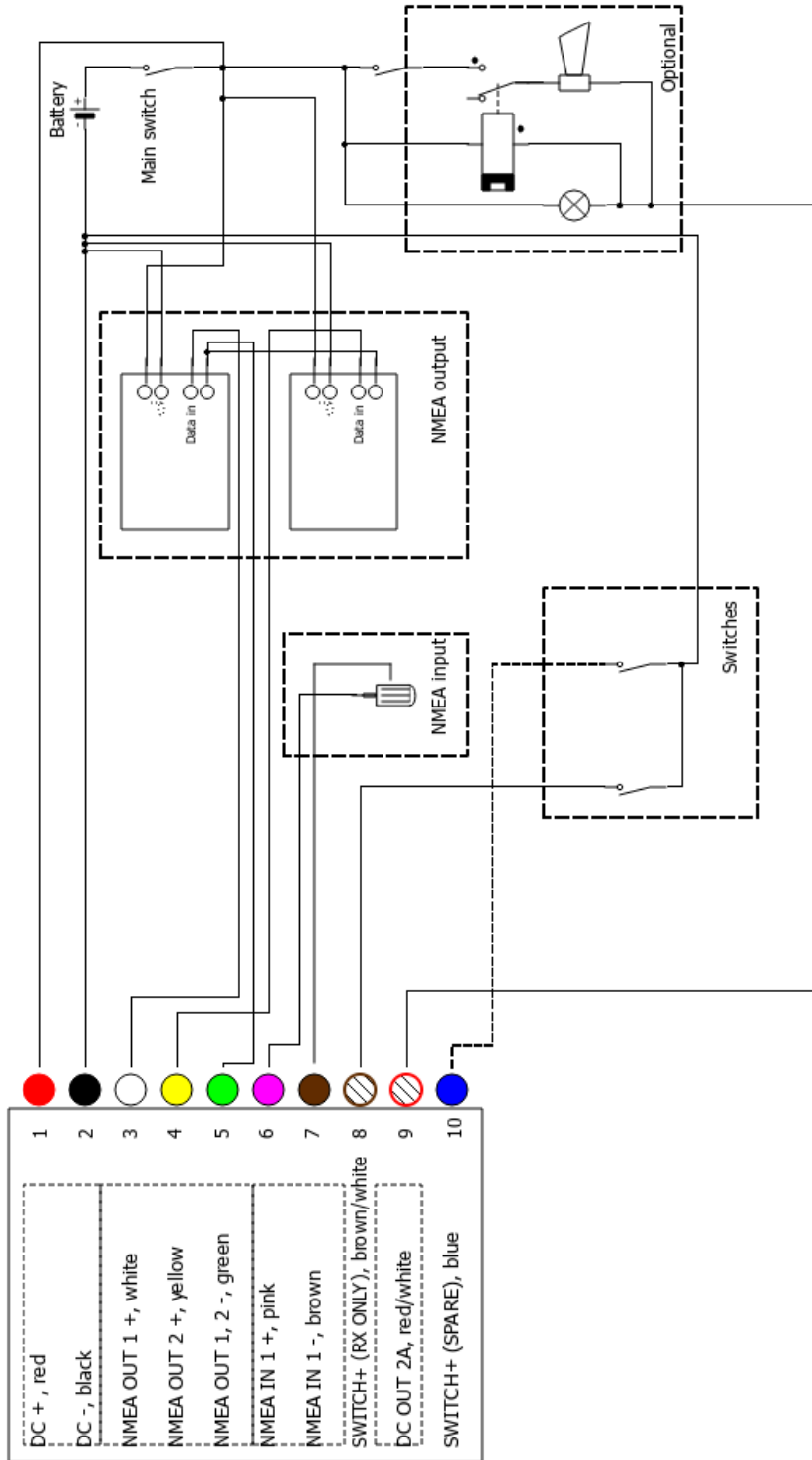

Figure 9 Connection Diagram

14 Fault diagnosis / Troubleshooting

Problem	Cause	Solution
No connection to the easyTRX3S	USB cable not plugged in correctly. USB driver was not installed correctly. Device configured correctly?	Install the Windows driver for the USB serial interface (FTDI) from the Internet.
No output of the data	Not connected	Repeat configuration, contact service partner if necessary Check the connection, are the cable colours correct? Is the data output of the easyTRX3 device connected to the data input of the plotter? Is the data rate of the NMEA interface of the plotter (target: 38400 baud!)
MMSI input not possible	Programmed already?	The MMSI cannot be programmed twice. Please contact your supplier or service partner.
Red Error-LED is on	div. Errors possible	Please connect to the programming tool and read the error in the 'Diagnostics' tab. If you are unable to rectify the error, please contact your dealer.

Figure 10 Troubleshooting

15 Error Messages / Warning Messages

Code	Group	Text	Meaning
001	Error	AIS: TX malfunction	
002	Error	AIS: Antenna VSWR exceeds limit	please check coaxial cable to your antenna and also connectors, too much power is reflected and that error is generated
003	Error	AIS: RX channel 1 malfunction	no AIS reception on Channel A, 161.975MHz
004	Error	AIS: RX channel 2 malfunction	no AIS reception on Channel B, 162.025MHz
005	Error	AIS: RX channel 70 malfunction	
007	Error	AIS: UTC Sync invalid	no GPS position
026	Error	AIS: no GPS since 30min	no GPS position
029	Error	AIS: no valid SOG information	no GPS position
030	Error	AIS: no valid COG information	no GPS position
050	Warning	AIS: GPS: no valid fix	no GPS position
051	Warning	AIS: High supply voltage	supply voltage more than 31.2V in idle mode
054	Warning	AIS: Base station has stopped TX	AIS Base station stopped your AIS Transmission within an local area, will be activated after a while or when you leave that area.
055	Warning	AIS: No MMSI	Due to no programmed MMSI, there is no AIS transmission, please fill in your MMSI
072	Error	AIS: low supply voltage	supply voltage less then 9,6V in idle mode
073	Error	AIS: low supply voltage while sending	due to thin cable or bad battery, the voltage drops on AIS transmission
077	Error	AIS: Device overheated	unit is getting too warm and will shut down e.g. WiFi to reduce currend and cooling down
078	Error	AIS: Baseband fail	

Figure 11 Error Messages

16 Maintenance

The devices in the easyTRX3S series have no parts that require maintenance. To clean the device, please use a damp cloth and do not use cleaning agents containing solvents or scouring powder.

Opening the appliance will invalidate the warranty.

17 Contact and Support

Although Weatherdock AG always endeavours to edit all publications with the utmost accuracy, these instructions may contain errors or ambiguities. In addition, changes to these instructions are the sole responsibility of Weatherdock and may be made without notice.

Frequently asked questions:

Visit our FAQ's (Frequently Asked Questions) at www.easyais.com/faqs

Contact:

Please contact your dealer first, as in most cases they will be able to help you quickly and easily.

If they are unable to help, we will be happy to help you directly:

Weatherdock AG
Emmericher Strasse 17
90411 Nürnberg
Tel: +49 911-37 66 38 30
support@weatherdock.de
www.easyais.de

Please contact your dealer first, as in most cases they will be able to help you quickly and easily.

If they are unable to help, we will be happy to help you directly.

18 Licence agreement

By using devices from the easyTRX3S series, you agree to the terms of the following warranty agreements.

Please read this agreement carefully.

Weatherdock AG grants you a limited licence to use the device in normal operation. Title, ownership rights and intellectual property rights in and to the software remain with Weatherdock AG.

19 Warranty

Weatherdock AG grants a warranty for this product of 2 years from the date of purchase for material and manufacturing defects in accordance with our terms and conditions, which you can view at www.easyAIS.de. Within this period, Weatherdock AG will, at its own discretion, repair or replace defective components in normal use. Repairs or replacements will be made without charge for parts or labour. However, the customer shall bear the shipping costs. This warranty does not apply to misuse, abuse, accidents or unauthorised modifications or repairs.

The warranties and rights contained herein are exclusive and are in lieu of all other warranties and or conditions, express or implied, including any statutory or other liability arising from any warranty of merchantability or fitness for a particular purpose. This warranty gives you specific legal rights depending on how long it lasts. In no event shall Weatherdock AG be liable for incidental, special, indirect or consequential damages arising out of the use or inability to use the product or any defect in the product. Weatherdock AG reserves the sole right to repair or replace the device or software or to refund the purchase price. This right is its sole and exclusive right in the event of a warranty claim.

Products purchased in online auctions do not entitle the buyer to discounts or to take advantage of Weatherdock AG's special offers. Purchase confirmations from online auctions are also not recognised as proof for warranty claims. An original proof of purchase from the dealer is always required to satisfy warranty claims. Weatherdock AG will not replace any missing device or accessory parts in products purchased in online auctions. In the event of a warranty claim, please contact your Weatherdock AG dealer. He will coordinate the further procedure with you. If the device is to be shipped, pack it carefully and send it with sufficient postage to the address given to you by your dealer. For warranty repairs, always enclose a copy of the original purchase receipt as proof of ownership. The Weatherdock AG easyTRX3 does not contain any user-serviceable parts.

If a problem occurs with your appliance, please contact your dealer.

Any attempt to open, change or modify the appliance will invalidate the warranty and may irreparably damage the appliance.

20 WARNING

When driving a vessel, it is the sole responsibility of the skipper to operate the vessel in a safe manner and to have full control of all driving conditions throughout the journey. Incorrect behaviour by the driver of a vessel equipped with the easyTRX3, where the driver does not pay full attention to the operation of the vessel and the surrounding conditions, can lead to an accident or collision resulting in damage to property or personal injury.

21 Your Notes

INDEX

- AIS Specification 51
- Anchor Alert 30
- Approval number BSH 2
- BSH Approval 52
- Certifications 51
- Collision warning 32
- Connection 13
- Connection-Diagramm 53
- Connectors 51
- Contact 56
- Course over Ground 26
- CPA 3
- CPA Alert 32
- Diagnostics 24
- Dimensions 50
- DVBT 49
- Error Messages 55
- External signalling device 10
- External Switches 10
- Fault diagnosis / Troubleshooting 54
- Frequencies 51
- GNSS 3, 50
- HDOP 3, 26
- IGPS - integrated GPS Antenna 48
- integrated FM splitter 48
- Integrated Modular Design 48
- Interfaces 51
- IP-Adresse 15
- Kontakt 56
- LAN 3
- Latitude / Longitude 26
- Licence agreement 56
- List of abbreviations 3
- Long-Range AIS 20
- Maintenance 56
- ME SENSE 35
- MMSI 3
- N2K - integrated NMEA2000 Module 49
- NMEA 3
- On-board voltage 50
- On-board installation 50
- Operating temperature range 50
- Operating voltage range 50
- Optional Modular Design 49
- Outstanding features of the easyTRX3S 7
- Passwort 15
- Port 15
- Power input 50
- Preparations 11
- Problem 54
- Reception sensitivity 51
- Reverse Power 27
- Routing 21
- RX only 10, 51
- Safety Distance 50
- Satellite AIS 20
- Satellites in view/used 26
- Scope of Delivery 5
- Sent Data 34
- Short description easyTRX3S 7
- Speed over Ground 26
- SSID 3, 15
- Supply Voltage 27
- Target Filtering 23
- Technical Data 50
- Transmission Power 51
- TX Forward Power 27
- USB Verbindung 12
- Version 28
- VHF 3
- VSWR 3
- Warning 57
- Warning Messages 55
- Warranty 57
- Weight 50
- WiFi 3
- WiFi - integrated WiFi Module 49
- WiFi & app use 14

Emmericher Strasse 17
90411 Nürnberg – Germany
+49 (0)911 – 37663830
info@weatherdock.de
support@weatherdock.de
www.easyais.com



EXCELLENCE IN RADIO TECHNOLOGIES
Safety • Navigation • Tracking

